

Crazy Diamond

design by Giuseppe Viganò 2015



Structure: wood.

Seat upholstery: expanded polyurethane of varied densities (D35+D40+D50 Mind Foam®); outer cover in 100% downproof white cotton filled with down and synthetic lining 230gr.

Back upholstery: expanded polyurethane of varied densities (D28+D21+D75); outer cover in 100% downproof white cotton filled with down and quilted synthetic lining 230gr.

Arm upholstery: expanded polyurethane of varied densities (D35+D40); outer cover in 100% downproof white cotton filled with down and coupled Dacron 380gr.

Springing: elastic belts.

Seat height: 41 cm

Arm height: 58 cm

Feet: metal, finishes micaceous brown or titanium, h. 11,5 cm.

On request feet can be supplied 3 cm higher by using spacers that may be at sight.

Attention: The back is supplied with a movement that allows two positions: a deep seat with high back and a reduced depth seat with a low back. The position can be changed through a simple action while seated.

By some compositions the standard feet where the two units are joined are replaced by central feet.

Struttura: legno.

Imbottitura seduta: poliuretano espanso a quote differenziate (D35+D40+D50 Mind Foam®), rivestito con cotone 100% antipiuma bianco riempito in piuma naturale 100%, fianchi in tomana gr.230.

Imbottitura schienale: poliuretano espanso a quote differenziate (D28+D21+D75), rivestito con cotone 100% antipiuma bianco riempito in piuma naturale 100%, fianchi in tomana trapuntata gr.230.

Imbottitura bracciolo: poliuretano espanso a quote differenziate (D35+D40), rivestito con cotone 100% antipiuma bianco riempito con 100% di piuma naturale, fianchi interni in dacron accoppiato gr.380.

Piano di molleggio: cinghie elastiche.

Altezza seduta: 41 cm

Altezza bracciolo: 58 cm

Piedi: metallo, finiture marrone micaceo o titanio, h.11,5 cm.

Su richiesta al momento dell'ordine è possibile avere piedi più alti di 3 cm. previo inserimento di distanziali che potrebbero essere visibili.

Attenzione: lo schienale è ingegnerizzato per avere due posizioni: seduta profonda con schienale alto e profondità di seduta ridotta con schienale basso. La variazione di posizione si ottiene grazie ad un semplice gesto stando comodamente seduti. In alcune composizioni i piedi di serie nel lato di unione degli elementi vengono sostituiti da piedi centrali di collegamento.

Covers with the following thick fabrics will be supplied without stitching, as indicated in the drawing "A":

- Vintage,
- Duchess,
- Vellu',
- Glamour,
- Fusion,
- Euphoria,
- Moire',
- Mousse,
- Deep,
- Dynamo.

I rivestimenti nei seguenti tessuti vengono realizzati senza cuciture, come indicato nel disegno "A"

- Vintage,
- Duchess,
- Vellu',
- Glamour,
- Fusion,
- Euphoria,
- Moire',
- Mousse,
- Deep,
- Dynamo.

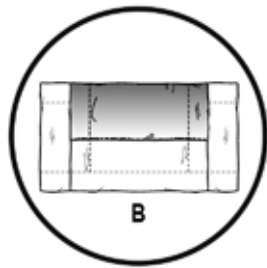
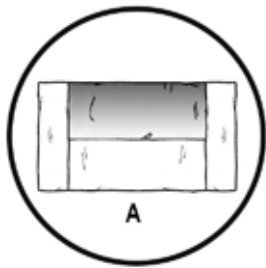

Sofa
Divano

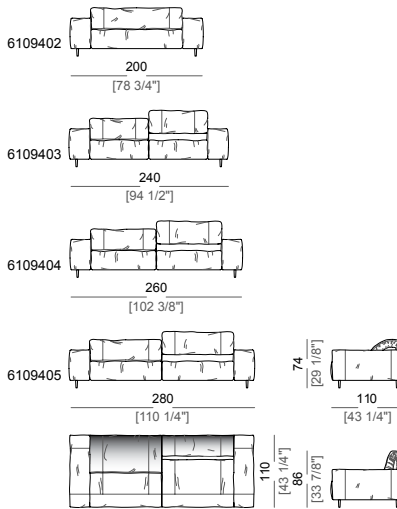

Sofa made by 2 units
Divano formato da due laterali

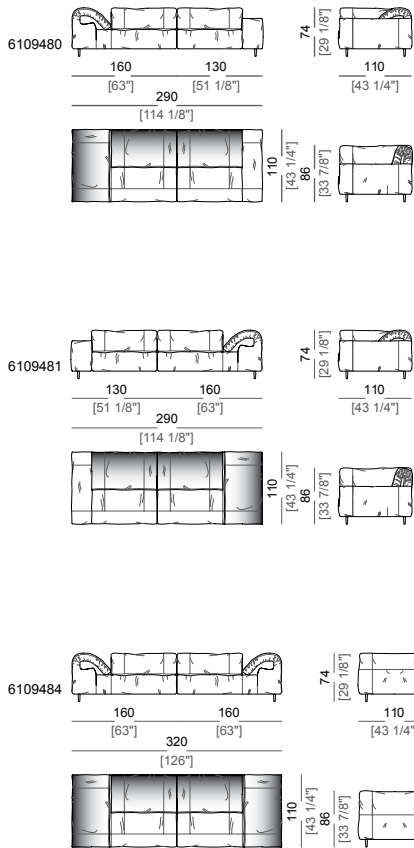

Sofa made by 2 units
Divano formato da due laterali

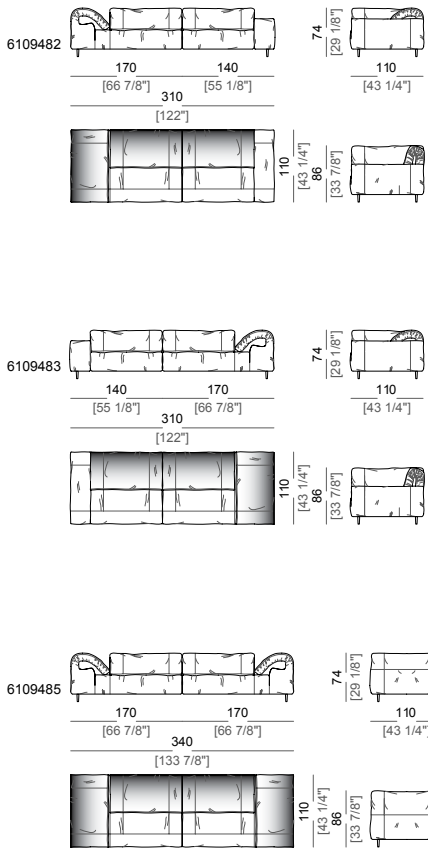

Right or left unit

Elemento laterale dx o sx

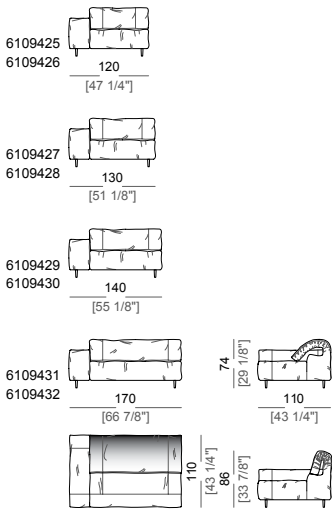

Right or left unit

Elemento laterale dx o sx

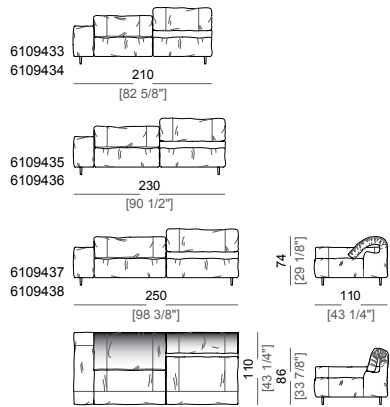

Unit with right or left pouf

Elemento laterale con pouf dx o sx

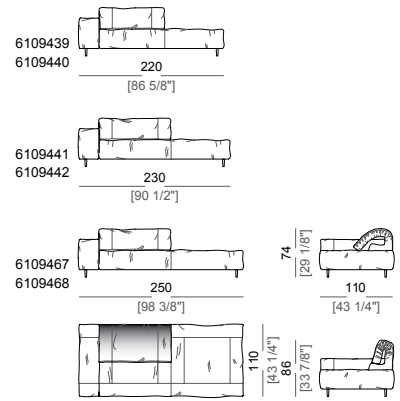

Central unit

Centrale

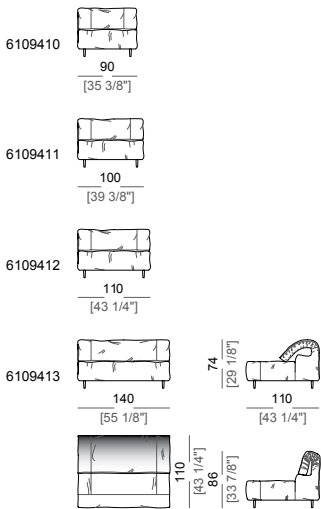

Central unit

Centrale

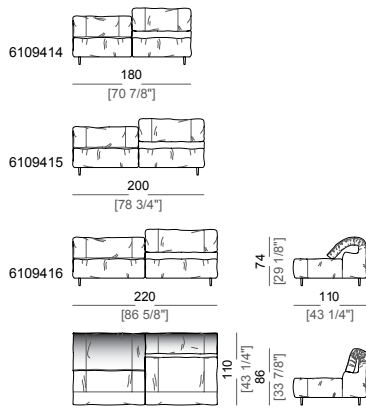

Central unit with right or left pouf
Centrale con pouf dx o sx

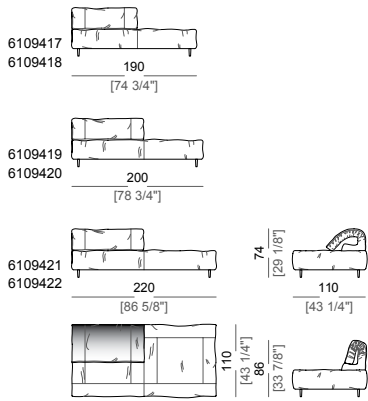

Fix central unit (STILL)
Centrale fisso (STILL)

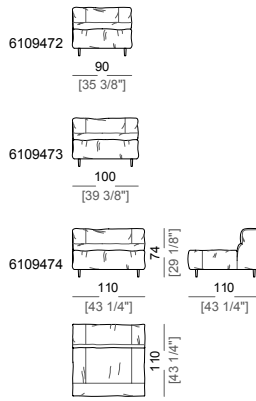

Fix central unit (STILL)
Centrale fisso (STILL)

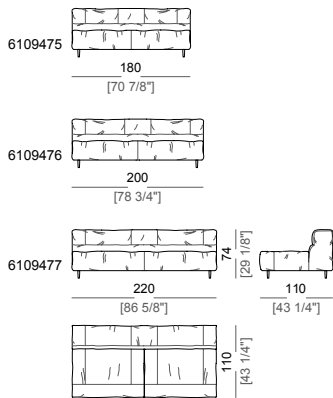

Right or left corner unit
Laterale angolare dx o sx

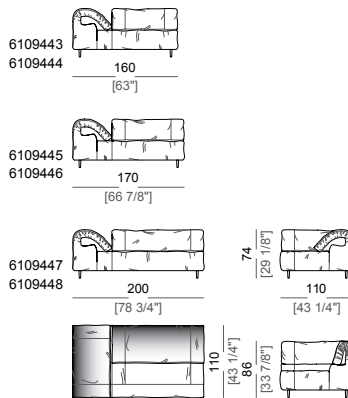

Right or left corner unit
Laterale angolare dx o sx

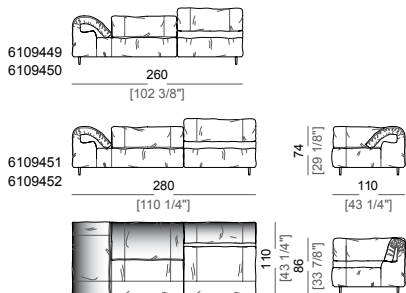

Corner unit with right or left pouf
Laterale angolare con pouf dx o sx

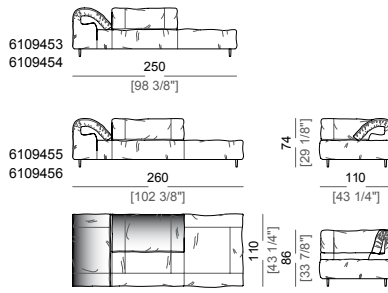

Chaise-longue with right or left short arm
Chaise longue dx o sx

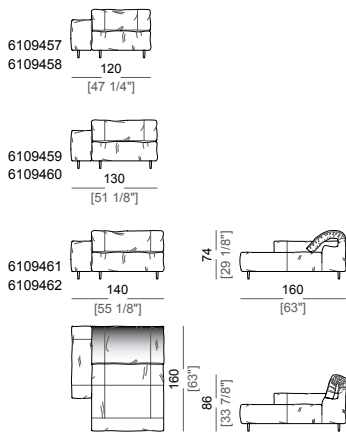

Dormeuse
Dormeuse

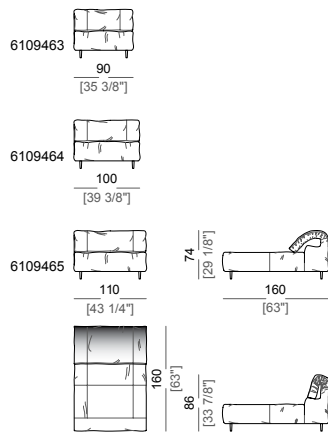

Pouf
Pouf

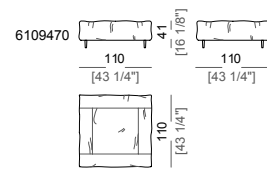

Composition E
Composizione E

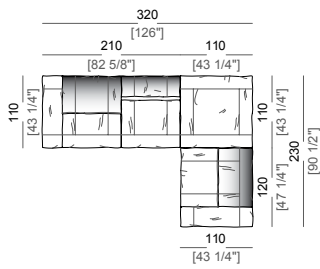

Composition F
Composizione F

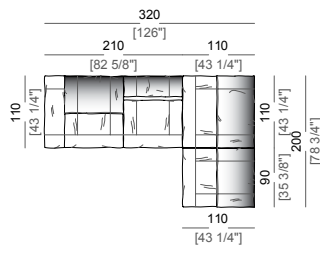

Composition G
Composizione G

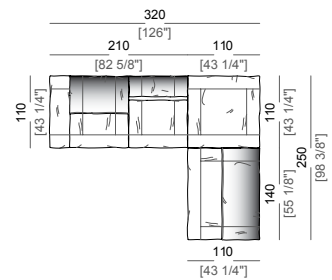

Composition H
Composizione H



Composition I
Composizione I

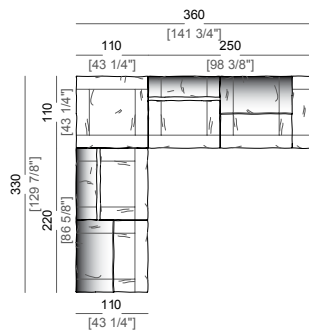

Composition L
Composizione L



Composition M
Composizione M

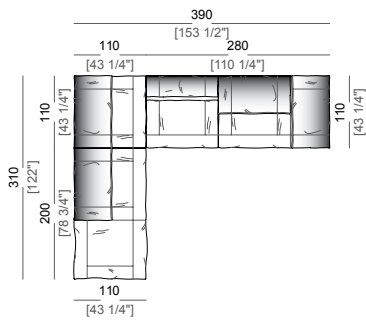

Composition N
Composizione N

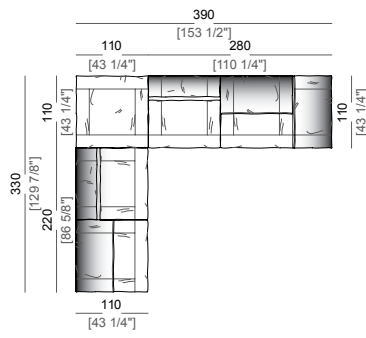

Composition O
Composizione O

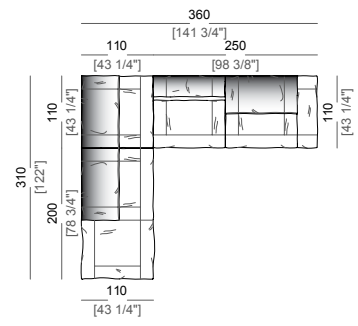

Composition P
Composizione P



Composition R
Composizione R

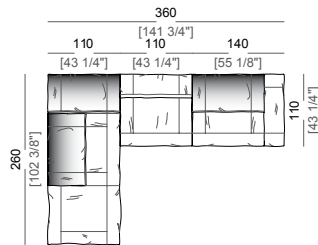

Composition S
Composizione S

